

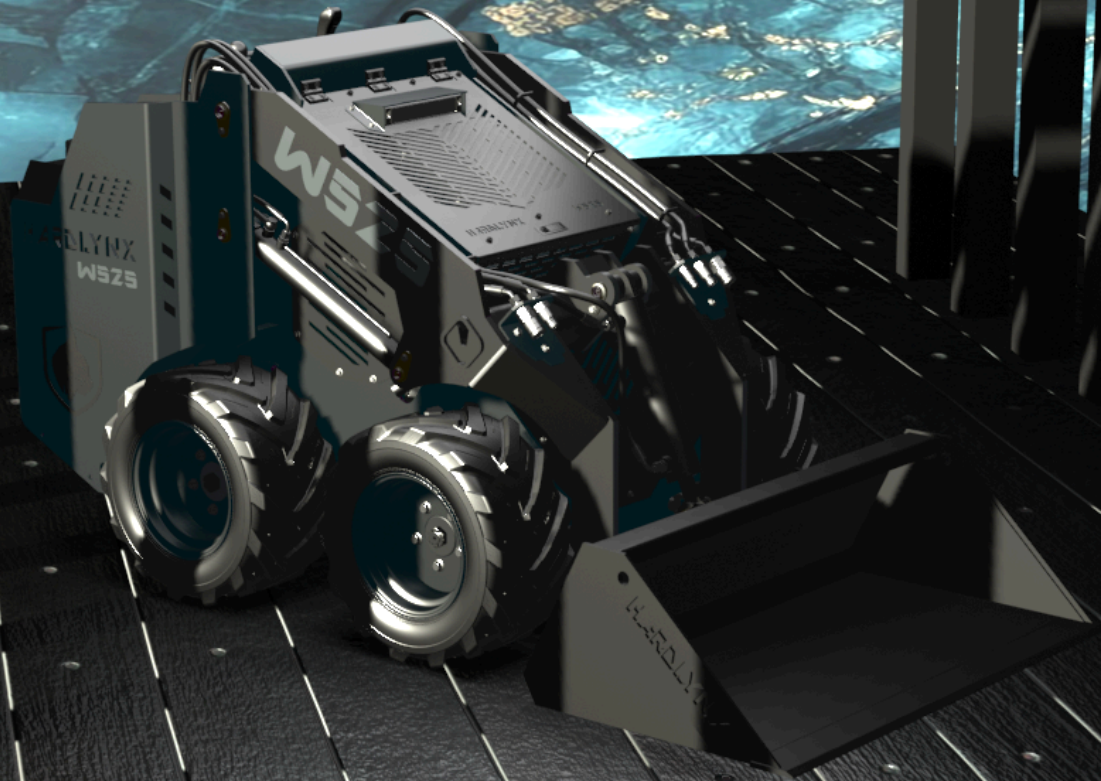

HARDLYNX



HARDLYNX W525 MINI SKID STEER LOADER



Technical specification

HARDLYNX W525 - Mini skid steer loader

Technical specification

GENERAL SPECIFICATIONS

Rated load capacity (ISO)	300 kg
Tipping load (ISO)	600 kg
Hinge pin height	2150 mm
Ground clearance	167 mm
Maximum travel speed	5.5 km/h

WEIGHTS

Operating weight	1500 kg
Machine weight (w bucket)	1425 kg

ENGINE

Make / Model	Kubota D1105-E4B
Emission regulation	EPA Tier 4 + EU Stage V
Engine type	Water cooled 4 cycle diesel engine with 3 cylinder
Displacement	1.123 l
Gross power	18.5 kW (24.8 HP) / 3000 rpm
Maximum torque	71.5 Nm / 2200 rpm

WHEELS

Standard tires	23x10.50-12
----------------	-------------

DRIVE SYSTEM

Main drive	Fully hydrostatic, 4 wheel drive
Transmission	Direct drive of hydraulic motor to wheel

HARDLYNX W525 - Mini skid steer loader

Technical specification

HYDRAULIC SYSTEM

Pump manufacture	Bondioli & Pavesi
Pump type	2x piston, 1x gear
Auxiliary oil pressure	180 bar
Auxiliary oil flow	44 l/min

TANK CAPACITIES

Fuel tank	38 l
Hydraulic tank	38 l

OPERATIONAL

Steering	Single, pilot operated joystick
Lift and tilt	Single, dual-axis joystick

ELECTRICAL SYSTEM

Voltage	12 V
Battery capacity	72 Ah

STANDARD BUCKET

Width	125 cm
Capacity	0.23 m ³
Cutting edge	Hardox HB500

HARDLYNX W525 - Mini skid steer loader

Technical specification

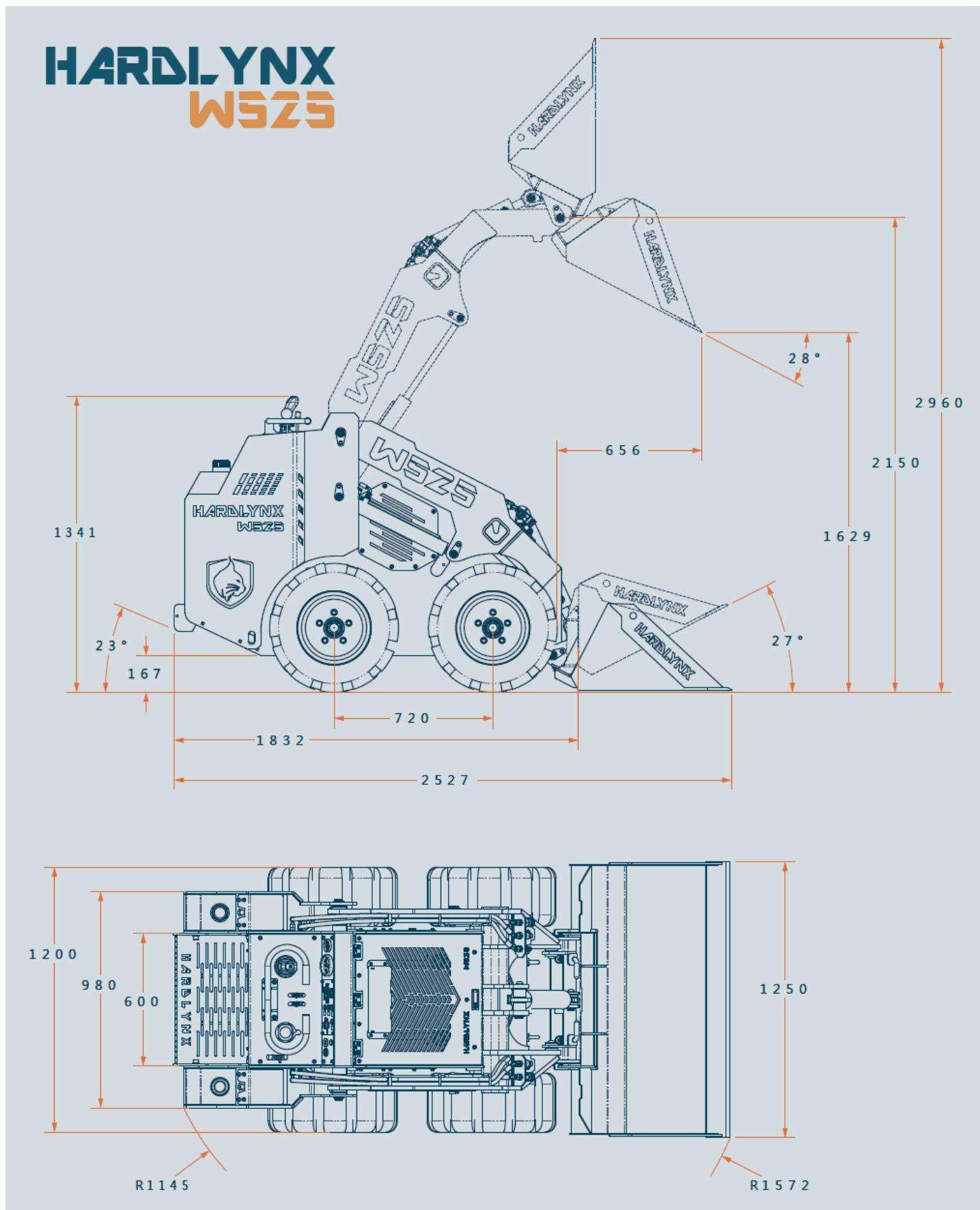

HARDLYNX s.r.o.

We reserve the right to improve our products and make changes in specifications and designs without notice.

www.hardlynx.sk
info@hardlynx.sk
+421 918 826 267